

THIS DRAWING, ENGINEERING REPORT OR DOCUMENT IS COPYRIGHT AND PROPERTY IS RESERVED THEREIN AND THE INFORMATION CONTAINED THEREIN IS CONFIDENTIAL. THIS DRAWING, ENGINEERING REPORT OR DOCUMENT AND INFORMATION MAY NOT BE REPRODUCED OR COMMUNICATED TO A THIRD PARTY OR USED FOR ANY PURPOSE OTHER THAN THAT FOR WHICH IS SUPPLIED WITHOUT THE PRIOR WRITTEN CONSENT OF PETER JACKMAN.

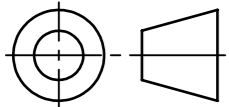

DO NOT SCALE.
IF IN DOUBT ASK.
BS 8888

THIRD ANGLE PROJECTION

A3

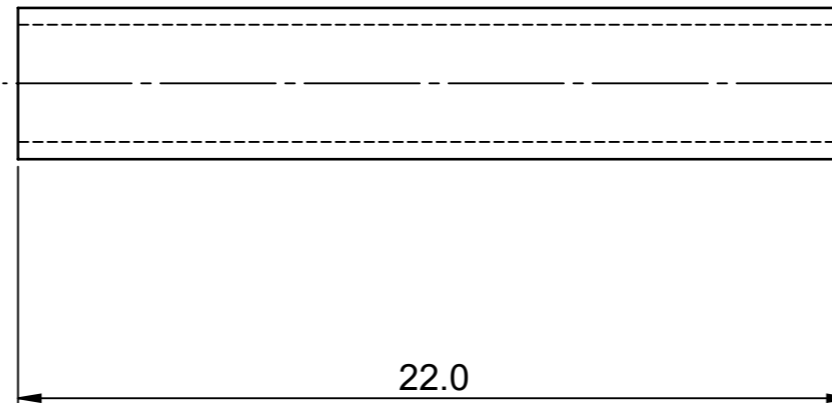
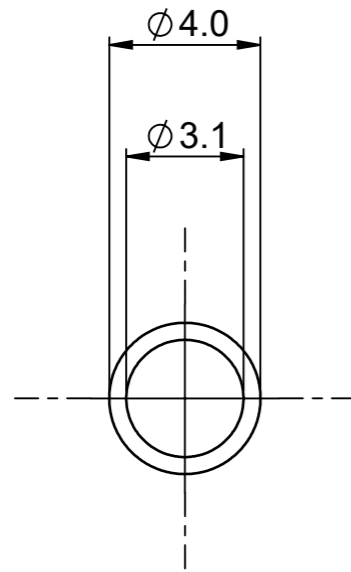

LAST CHANGE DETAIL			KEY CHARACTERISTICS IDENTIFIED BY THE FOLLOWING SYMBOL			TOLERANCES UNLESS STATED	DIMENSIONS mm	UNLESS OTHERWISE STATED CHAMFER OR RADII 0.13 (0.005") MAX. REMOVE BURRS & SHARP EDGES. DIMENSIONS APPLY AFTER PLATING			
ISS.	DATE	DRAWN	ISS.	DATE	DRAWN	0. ± 0.4 0.0 ± 0.1 0.00 ± 0.05 ANGULAR ± 0.5°	ESTIMATED MASS 0.94g	MATERIAL Brass		TITLE PUG CYLINDER LINER LINER	
A	29/05/2023	P.R.J.				SURFACE FINISH 3.2/	SCALE 5:1	FINISH SELF COLOUR	MADE FROM ALBION ALLOYS CT4M	DRAWING NUMBER PUG CYL LINER	SHEET 1 OF 1